

IMPORTANT SAFETY INSTRUCTIONS

1. Read these instructions.
2. Keep these instructions
3. Heed all warnings.
4. Follow all instructions.
5. Do not use this apparatus near water.
6. Clean only with dry cloth.
7. Install in accordance with the manufacturer's instructions.
8. Do not install near any heat sources such as radiators, heat registers, stoves, or other apparatus that produce heat.
9. Use only attachments/accessories specified by the manufacturer
10. Use only with a cart, stand, tripod, bracket or table specified by the manufacturer, or sold with the apparatus. When a cart is used, use caution when moving the cart/apparatus combination to avoid injury from tip-over.
11. Unplug this apparatus during lightning storms or when unused for long periods of time.
12. Refer all servicing to qualified service personnel. Servicing is required when the apparatus has been damaged in any way, such as power supply cord or plug is damaged, liquid has been spilled or objects have fallen into the apparatus, the apparatus has been exposed to rain or moisture, does not operate normally, or has been dropped.
13. This apparatus shall not be exposed to dripping or splashing, and no object filled with liquids, such as vases, shall be placed on the apparatus.
14. Any changes or modifications not expressly approved in this manual could void your authority to operate this apparatus.

COMPLIANCE



The Black Lion Audio PBR-8 complies with all applicable CE / RoHS / WEEE European Union directives.

Do not attempt to service this unit yourself, as it will void your warranty. Please check your unit carefully upon receipt and return to place of purchase immediately if there are any problems with the product. After that, the standard Black Lion Audio 3 YEAR warranty will apply to defects in materials and workmanship.

U.S.A.

Should your Black Lion Audio product require service, please contact us on our customer service site: <https://www.blacklionaudio.com/contact>. You must obtain an RA # (Return Authorization number) from us before shipping a unit back to us. This RA # must be clearly written on the outside of the box.

Please safely pack the units..It is best to use the original packing materials. Black Lion Audio cannot be responsible for any damages incurred in shipping to us due to poor packaging. PLEASE PACK CAREFULLY and FULLY INSURE THE SHIPMENT.

INTERNATIONAL

For service or warranty assistance, please contact the Black Lion Audio distributor in your country through the dealer from whom you purchased this product.

LIMITED 3 YEAR WARRANTY

Black Lion Audio's PBR-8 is warranted by Black Lion Audio to be free from defects in materials and workmanship for the period of THREE (3) YEARS to the original purchaser. In the event of such defects, the product will be repaired without charge or, at our option, replaced with a new one if delivered to Black Lion Audio prepaid, together with a copy of the sales slip or other proof of purchase date. The warranty excludes problems due to normal wear, abuse, shipping damage or failure to use the product in accordance with the specifications.

All parts and labor are covered under this Limited Warranty. However, if it is determined by Black Lion Audio that the device was damaged or made defective through abuse, we reserve the right to charge the customer for the cost of the repair.

Black Lion Audio shall not be liable for damages based upon inconvenience, loss of use of the product, loss of time, interrupted operation or commercial loss or any other damages, whether incidental, consequential or otherwise. This warranty gives you specific legal rights, and you may have other rights, which will vary from state to state.

This warranty is not transferable.

Notice

This manual provides general information, preparation for use, installation and operating instructions for the Black Lion Audio PBR-8.

The information contained in this manual is subject to change without notice. Black Lion Audio makes no warranties of any kind with regard to this manual, including, but not limited to, the implied warranties of merchantability and fitness for a particular purpose. Black Lion Audio shall not be liable for errors contained herein or direct, indirect, special, incidental, or consequential damages in connection with the furnishing, performance, or use of this material.

©2023 Black Lion Audio. The Black Lion Audio 'Lion Face' logo, B.L.A. are trademarks or registered trademarks of Black Lion Audio. This manual and any associated intellectual property are subject to copyright protection. No part of this document may be reproduced in any form without explicit written consent from Black Lion Audio.



PBR-8

PBR-8 - 500 Series 8-Slot
Rack with Built-in Patchbay

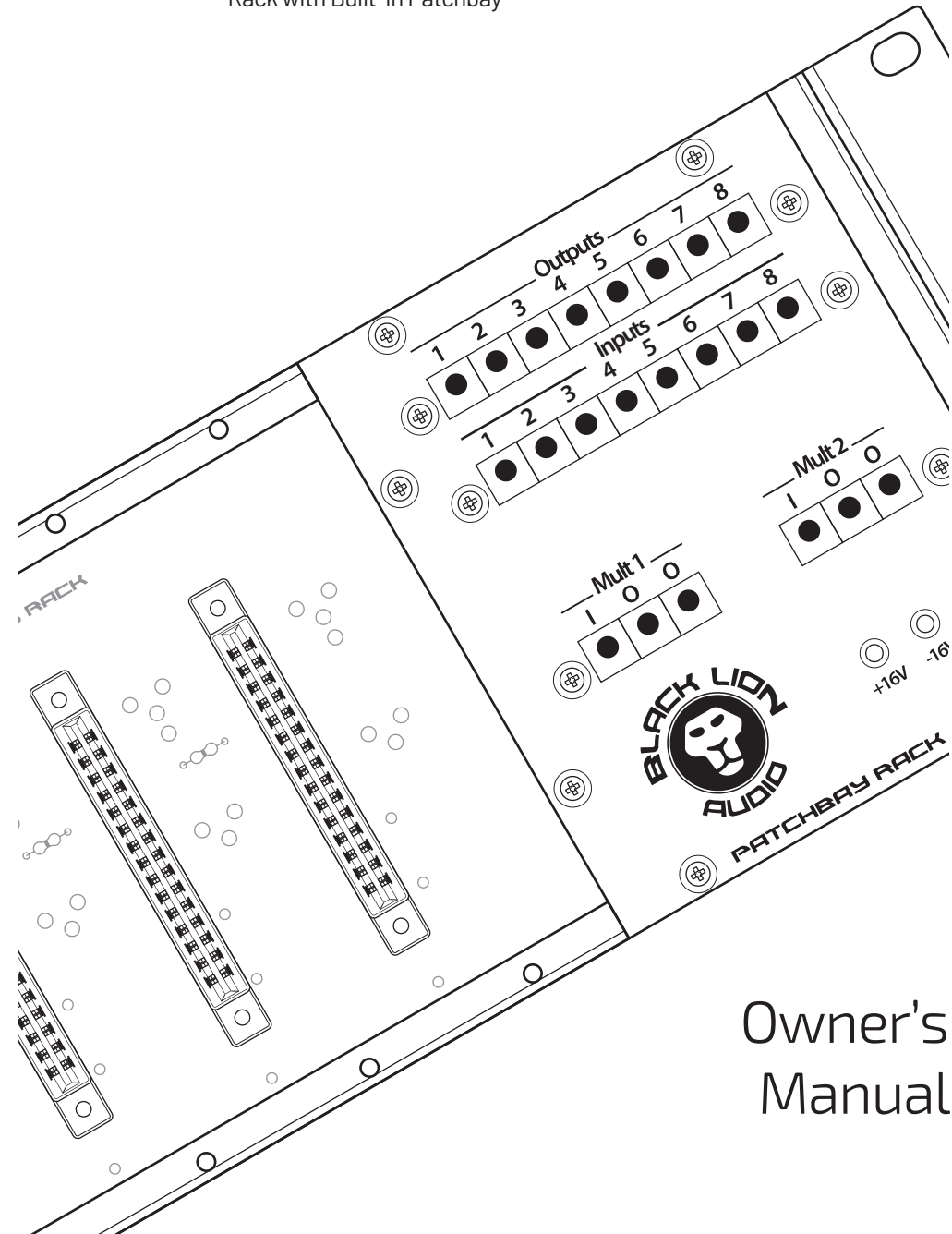

Owner's Manual

QUICK START GUIDE

PBR-8 SETUP

1. Mute your studio monitors.
2. Connect the PBR-8 to the appropriate inputs and outputs of your mixer or interface using balanced XLR cables or the DB25 jacks on the rear of the PBR-8.
3. Connect the PBR-8 to power.

INSTALLING A MODULE

Note: The PBR-8 isn't very fun when no modules are installed. **DO NOT attempt to install or remove a module while the unit is powered on! Many modules will not accept being hot-swapped, and expensive damage will result!**

1. Inspect PBR-8 and your 500-series module and make sure nothing is surrounding the card edge connectors.
2. Power off the PBR-8.
3. Carefully slide your 500-series unit into an empty slot in your PBR-8.
4. Make sure the module connector sits well into the mating EDAC chassis connector.
5. Secure the 500-series module to the PBR-8 chassis using the included M3 screws.
6. Power on the PBR-8.

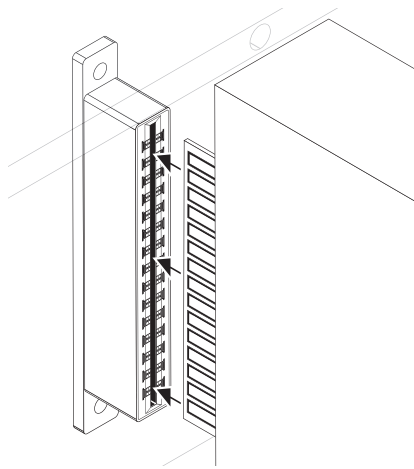

PATCHING

Use TT/Bantam cables with the PBR-8's front-mounted patchbay to quickly create new signal chains and routing among your installed modules. Split your signal using a Mult for parallel processing, put your compressor before your EQ... experiment!

Be careful not to route a module's output to its own input, loud feedback loops can occur.

ON SLOT TECHNOLOGY (OST)

This included Heritage Audio Technology provides individual regulation per channel, ensuring that noise, power issues, or crosstalk from one module does not affect other modules. The hefty power supply provides 400mA per rail per slot maximum.

SPECIFICATIONS

Voltage	100-240VAC
Maximum audio rails current:	1.8A per rail, or 400mA per rail per slot, whatever is reached first
Dimensions	Width: 76 mm (3") Height: 178 mm (5.25") Depth: 191 mm (7.5")
Weight	4.4 kg (9.7 lbs)

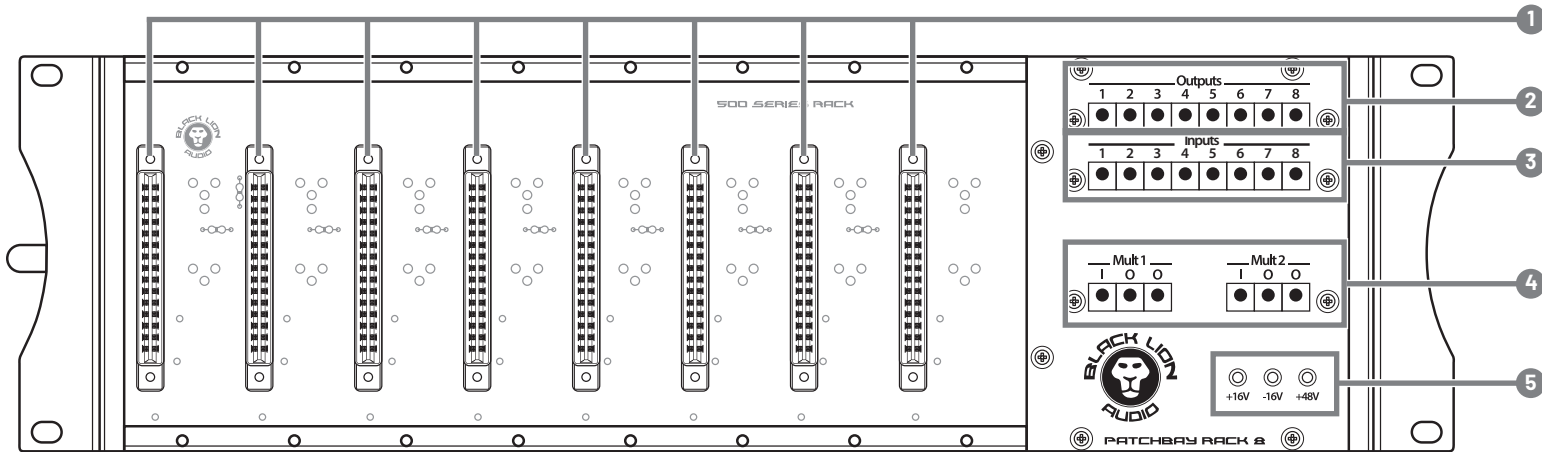

CONTROLS

1. **EDAC Connectors:** Connect your 500-series modules here, as described in "Installing a Module" section.
2. **Patch Outputs:** Access signal from any of your modules connected to the eight EDAC Connectors.
3. **Patch Inputs:** Send signal to any of your modules connected to the eight EDAC Connectors.
4. **Mult 1 and Mult 2:** Split one input signal into two output signals - simply connect any front-mounted output to a Mult 1 and tap the split signal from either or both of the Mult's 0 ports.
5. **Voltage indicators:** +16v, -16v, and +48v
6. **Rear DB25 Outputs:** Connect inputs to your mixer or interface via a DB25 cable with TASCAM pin configuration.
7. **Rear XLR Outputs:** Connect inputs to your mixer or interface via balanced XLR cables.
8. **Rear XLR Inputs:** Connect outputs from your mixer or interface via balanced XLR cables.
9. **Rear DB25 Inputs:** Connect outputs from your mixer or interface via a DB25 cable with TASCAM pin configuration.
10. **5-pin XLR power connection.** Connect the PBR-8 to your AC mains.

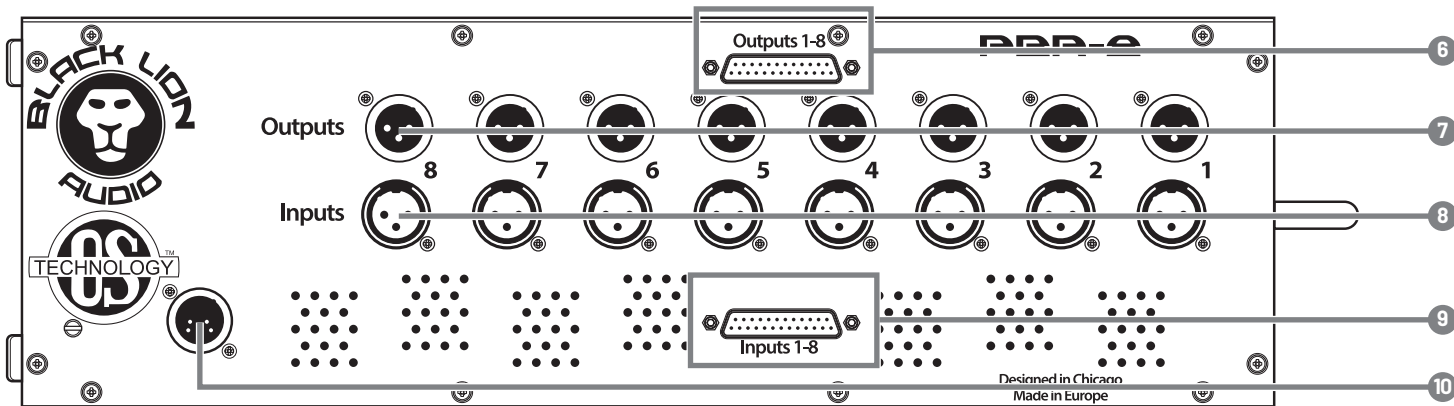

Note: For proper performance, balanced XLR must be used for all inputs and outputs.