

B173 500 | User Manual

TABLE OF CONTENTS

- Introduction3
- Features3
- Specifications4
- Package Contents4
- Front5
- Connection Diagram5
- Signal Flow/Hardware Block Diagram6
- Repair6
- Warranty6
- Disclaimer6
- Copyright7

INTRODUCTION

The B173 is one of the most “bang for your buck” preamps in existence, and is now available in the 500 series format. The B173 500 not only delivers the beefy lows, buttery mids, and polished highs of a classic 1073 preamp, but does so at a fraction of the price!

The preamp and line amp circuitry found in the B173 500 is identical to the original B173. Not a single component or design feature was compromised while converting it to a smaller package. As a result, the circuit boards are jam packed with all sorts of delicious components, including a brawny Cinemag input transformer!

The power supply is the backbone of any preamp design, and can make a huge impact on the overall sound and performance of the preamp. The +24V rail needed to power the B173 500 is painstakingly converted from the +/- 16V rails of a 500 series rack using a custom DC-DC converter circuit specially designed to keep any unwanted noise or modulations out of the signal path. Complete isolation is then achieved through the use of inductors, ferrite beads, decoupling capacitors, power regulation, and a custom enclosure surrounding the entire circuit.

The B173 500's “Class A”, discrete circuitry combined with high-end components provide a fresh approach to a classic sound that won't disappoint. Thanks for your purchase and continued support of Black Lion Audio!

FEATURES

- 500 Series format (500 series rack required for use)
- Cinemag Input Transformer
- Edcor Output Transformer
- 80dB Gain
- Hi-Z Input (passive, unbalanced)
- Phantom Power
- Phase Switch
- Output Attenuator

SPECIFICATIONS

Mic Section

- Max Microphone Input Level: +1 dBu
- Input Impedance: 200 Ω
- Gain: +12dB to +80dB
- Equivalent Input Noise (noise floor): -103dB
- THD+N (@ +4dBu output):
 - .072% @ +8 dBu Gain
 - .074% @ +29 dBu Gain
 - .082% @ +44 dBu Gain
 - .152% @ +60 dBu Gain
 - .709% @ +76 dBu Gain
- Bandwidth (1kHz, 150 Ω source, unweighted): 10Hz to 30kHz

Hi-Z Section

- THD+N (@ +4dBu output):
 - .0045% @ +10 dBu
 - .0076% @ +15 dBu

Output Section

- Max Output Level: +29dBu
- Output Impedance: 600 Ω

Power Supply

- +24V provided by ultra low noise, custom power supply (500 series rack required)

Product Dimensions

- 1.5" x 6.5" x 5.25"

Product Weight

- 1.2 lbs

Shipping Dimensions

- 13" x 13" x 5"

Shipping Weight

- 3 lbs

PACKAGE CONTENTS

- B173 500

FRONT

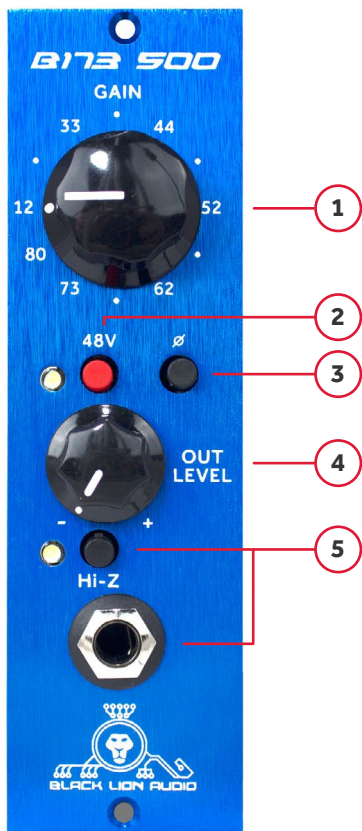

1. **GAIN (stepped, 12-position switch):** clockwise rotation yields an increase in input signal amplitude, counterclockwise rotation yields a decrease in input signal amplitude
2. **48V:** engage to turn phantom power on, disengage to turn phantom power off
3. **PHASE:** engage to adjust input signal polarity by 180°, disengage to leave input signal polarity unchanged
4. **OUT LEVEL:** clockwise rotation yields less attenuation, counterclockwise rotation yields more attenuation (for beginners, it's best to leave the output level fully clockwise and increase Gain as needed so as not to saturate the input transformer)
5. **Hi-Z:** engage to select faceplate TS jack as input source, disengage to select XLR input jack on 500 series rack as input source (GAIN does not adjust signal level, however, OUT LEVEL does attenuate the signal)

B173 500 CONNECTION DIAGRAM

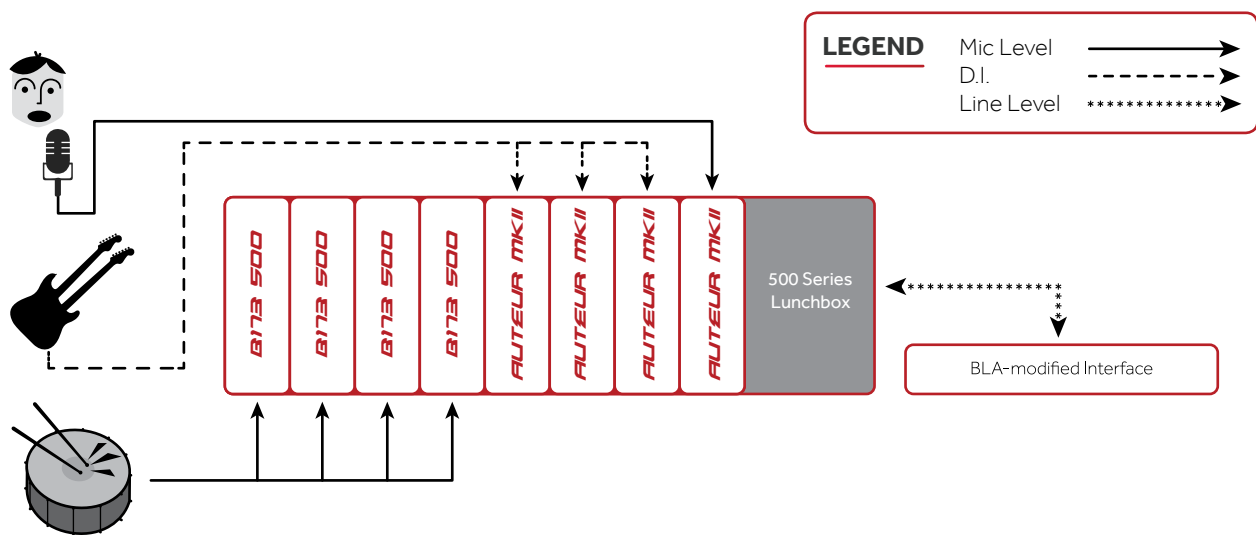

SIGNAL FLOW/HARDWARE BLOCK DIAGRAM

“GAIN” is a 12-position, stepped switch ranging from +12dB minimum gain to +80dB maximum gain. The majority of the gain for the microphone input comes from the mic amp gain stage. The signal passes through an input transformer before going to the mic amp gain stage, which is controlled by the “GAIN” rotary switch on the front panel. The signal then passes to the Hi-Z switch, which selects which input signal (mic or Hi-Z) goes to the output amplifier. The “OUT LEVEL” pot attenuates the signal before going to the output amplifier, which in turn goes to the output transformer (see chart below):

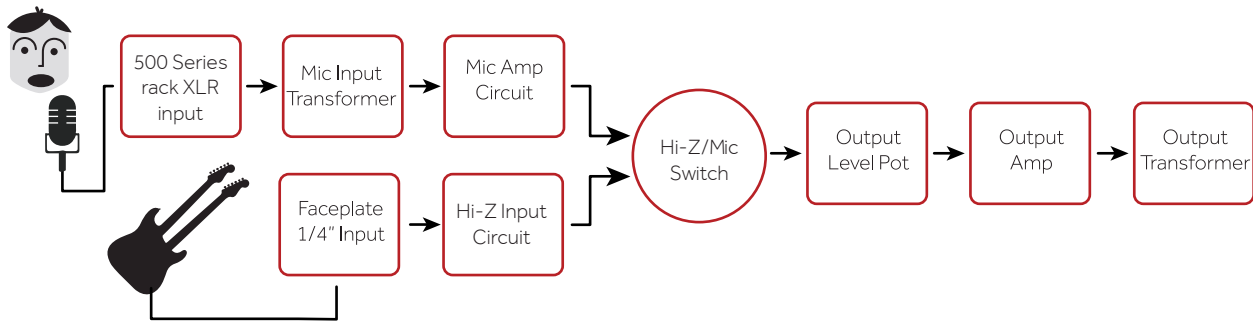

REPAIR

To reduce the risk of fire or electric shock, the user should not attempt to repair the device in the event of a failure. Repairs should be referred to qualified service personnel only. Please contact Black Lion Audio if you need assistance.

WARRANTY

We extend a three-year warranty on defects in materials and workmanship for all Black Lion Audio products from the date of purchase. This does not cover user error, wear, tear, or abuse. Should your B.L.A. product experience any problems or failures during the warranty period, immediately contact us, and we will gladly correct the issue at no charge (excluding shipping).

DISCLAIMER

For your safety, please read the following!

Grounding: For your safety, do not defeat the grounding connection. Use the device only when it is properly grounded.

Liquids, water and moisture: The device should not be used near water, or when it is wet. Care should be taken so that it remains dry. Be sure to keep the device away from rain or other moisture.

Power: The device must be loaded in and powered by a 500 Series rack

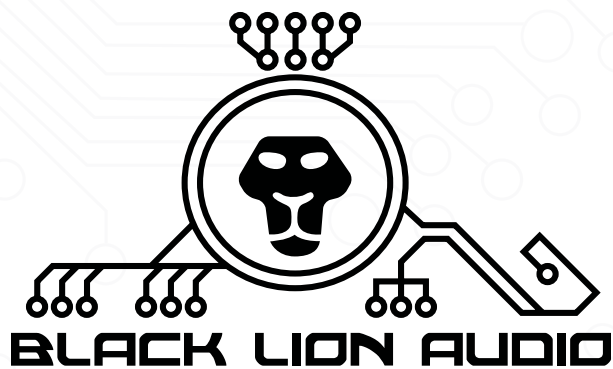

1801 W. BELLE PLAINE AVE., SUITE 105
CHICAGO, IL 60613

INFO@BLACKLIONAUDIO.COM

BLACKLIONAUDIO.COM

Copyright © 2016 Black Lion Audio, Inc. All rights reserved. This manual and any associated artwork, product designs, and design concepts are subject to copyright protection. No part of this document may be reproduced in any form without prior written permission of Black Lion Audio, Inc.