

**Notice**

This manual provides general information, preparation for use, installation and operating instructions for the Black Lion Audio Bluey.

The information contained in this manual is subject to change without notice. Black Lion Audio makes no warranties of any kind with regard to this manual, including, but not limited to, the implied warranties of merchantability and fitness for a particular purpose. Black Lion Audio shall not be liable for errors contained herein or direct, indirect, special, incidental, or consequential damages in connection with the furnishing, performance, or use of this material.

©2024 Black Lion Audio. The Black Lion Audio 'Lion Face' logo, BLA, are trademarks or registered trademarks of Black Lion Audio. This manual and any associated intellectual property are subject to copyright protection. No part of this document may be reproduced in any form without explicit written consent from Black Lion Audio.

**RAD Distribution**  
180 Carpenter Ave.  
Middletown, NY 10940

Revised 05-15-24



# Bluey

FET Limiting Amplifier

METER

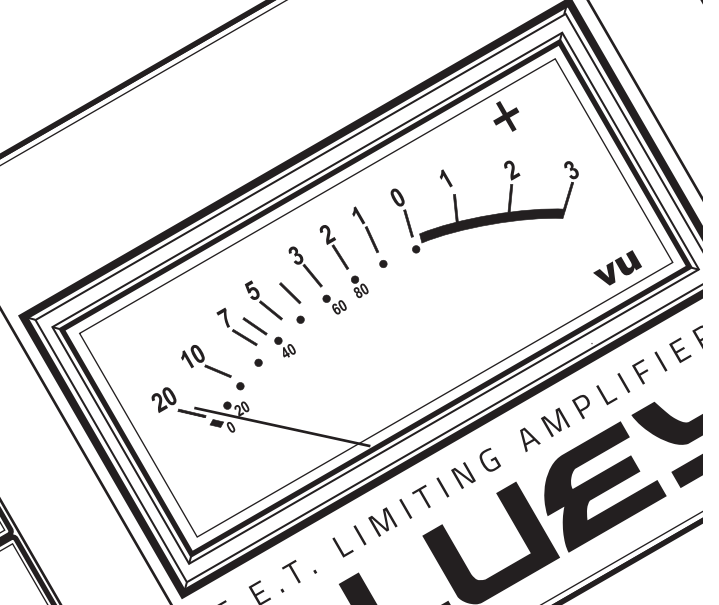
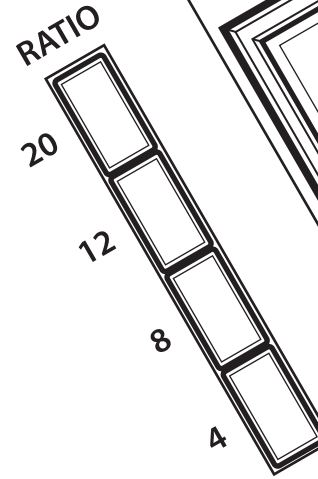

F.E.T. LIMITING AMPLIFIER  
**BLUEY**

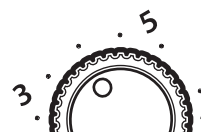
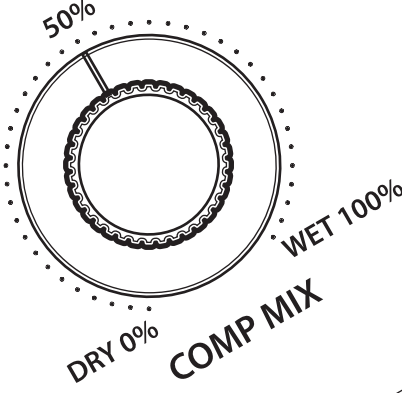
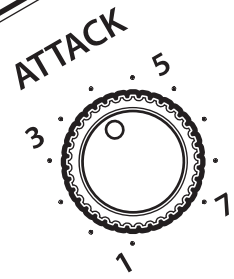

Owner's Manual

## IMPORTANT SAFETY INSTRUCTIONS

1. Read these instructions.
2. Keep these instructions
3. Heed all warnings.
4. Follow all instructions.
5. Do not use this apparatus near water.
6. Clean only with dry cloth.
7. Install in accordance with the manufacturer's instructions.
8. Do not install near any heat sources such as radiators, heat registers, stoves, or other apparatus that produce heat.
9. Do not defeat the safety purpose of the polarized or grounding-type plug. A polarized plug has two blades with one wider than the other. A grounding-type plug has two blades and a third grounding prong. The wide blade or third prong is provided for your safety. If the provided plug does not fit into your outlet, consult an electrician for replacement of the obsolete outlet.
10. Protect the power cord from being walked on or pinched particularly at plugs, convenience receptacles, and the point where they exit from the apparatus. If the power cord becomes frayed, stop using immediately.
11. Use only attachments/accessories specified by the manufacturer.
12. Use only with a cart, stand, tripod, bracket or table specified by the manufacturer, or sold with the apparatus. When a cart is used, use caution when moving the cart/apparatus combination to avoid injury from tip-over.
13. Unplug this apparatus during lightning storms or when unused for long periods of time.
14. Refer all servicing to qualified service personnel. Servicing is required when the apparatus has been damaged in any way, such as power supply cord or plug is damaged, liquid has been spilled or objects have fallen into the apparatus, the apparatus has been exposed to rain or moisture, does not operate normally, or has been dropped.
15. This apparatus shall not be exposed to dripping or splashing, and no object filled with liquids, such as vases, shall be placed on the apparatus.
16. Note that this apparatus is not completely disconnected from the AC mains service when the power switch is in the OFF position.
17. The mains plug or power inlet on the product is used as the disconnect device, so the disconnected device shall remain readily operable when reconnected.
18. Any changes or modifications not expressly approved in this manual could void your authority to operate this apparatus.

### IMPORTANT!

**Be sure to use a three prong AC cable that properly fits the power source. Please use the correct fuse designated on the rear panel before plugging in the power cord. Improper selection can result in damage to the unit that will not be covered under the warranty.**



to persons.

The exclamation point within an equilateral triangle is intended to alert the user to the presence of important operating and maintenance (servicing) instructions in the literature accompanying the product.

The Black Lion Audio Bluey complies with all applicable / RoHS/ WEEE European Union directives.



**Do not attempt to service this unit yourself, as it will void your warranty. Please check your unit carefully upon receipt and return to place of purchase immediately if there are any problems with the product. After that, the standard Black Lion Audio 3 YEAR warranty will apply to defects in materials and workmanship.**

### INTERNATIONAL

For service or warranty assistance, please contact the Black Lion Audio distributor in your country through the dealer from whom you purchased this product.

### LIMITED 3 YEAR WARRANTY

Black Lion Audio's Bluey is warranted by Black Lion Audio to be free from defects in materials and workmanship for the period of THREE (3) YEARS to the original purchaser. In the event of such defects, the product will be repaired without charge or, at our option, replaced with a new one if delivered to Black Lion Audio prepaid, together with a copy of the sales slip or other proof of purchase date. The warranty excludes problems due to normal wear, abuse, shipping damage or failure to use the product in accordance with the specifications.

All parts and labor are covered under this Limited Warranty. However, if it is determined by Black Lion Audio that the device was damaged or made defective through abuse, we reserve the right to charge the customer for the cost of the repair.

Black Lion Audio shall not be liable for damages based upon inconvenience, loss of use of the product, loss of time, interrupted operation or commercial loss or any other damages, whether incidental, consequential or otherwise. This warranty gives you specific legal rights, and you may have other rights, which will vary from state to state.

**This warranty is not transferable.**

### NOTES

#### Stereo linking

When running a pair of Blueys via a stereo link, start by setting both units to matched settings, as the detector circuits are the linked elements - not the controls. Note that due to design limitations of the 76-style compressors, no two units will ever be 100% matched without an external battery-powered balancing box. If you don't have a balancing box, you may need to make slight alterations to the Input and Output controls to create perfect stereo matching.

#### The Attack control

The Attack control on the Bluey works a little differently than you may have encountered on other 76-style compressors. Turning the Attack knob to the left (counter-clockwise) will yield faster attack times; slower times result when turning to the right (clockwise). We've found this control scheme to be more intuitive; akin to a volume knob decreasing level to the left and increasing to the right.

- **Attack:** Continuously variable 20  $\mu$ S to 800  $\mu$ S
- **Release:** Continuously variable 1200 mS to 50 mS

## QUICK START GUIDE

Mute your studio monitors. Using **balanced XLR cables**, connect your Bluey to your mixing bus or patch bay. If you are using two Blueys in parallel (or stereo), connect the two units using an RCA cable. Set all controls to full counter-clockwise position, and all pushbuttons deselected or in the off position. Press the On button to power the unit back up.

Unmute the monitors, and verify that signal is passing to and from the unit. Set the INPUT, OUTPUT, ATTACK and RELEASE controls to about 12 o'clock, set COMP MIX to full clockwise, select RATIO 4, and press the ON pushbutton. Increase the INPUT until the meter is deflecting a few dB. Again, verify signal is passing through the unit. Done!

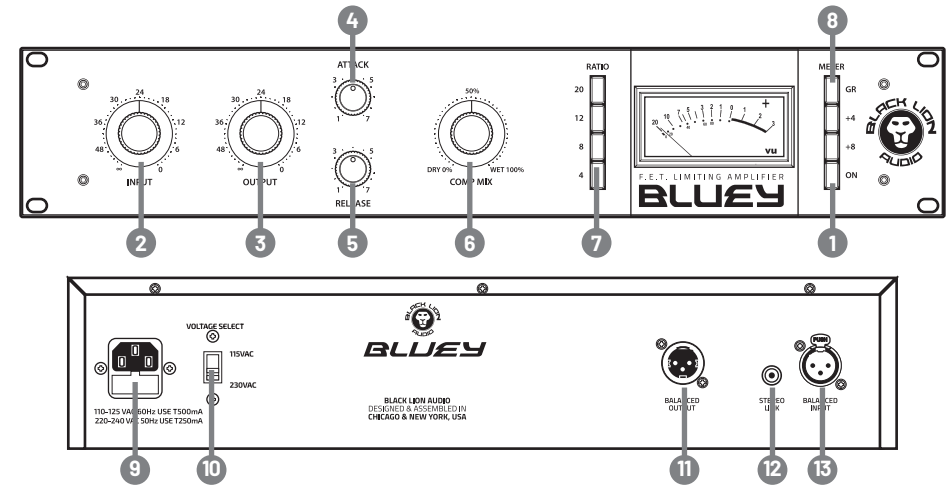

- 1. Power Button:** This turns the unit on and off.
- 2. Input:** Sets the threshold and controls the level at which the compressor starts compressing
- 3. Output:** Applies makeup gain to compressed signal to compensate for signal lost during compression
- 4. Attack:** Controls the amount of time it takes for the unit to react to an incoming signal
- 5. Release:** Controls the speed at which the compressor releases the compressed signal
- 6. Comp Mix:** Allows the user to blend the dry uncompressed signal with the wet compressed signal to allow more natural sounding compression
- 7. Ratio:** Controls the amount of compression applied (Yes, it does all-buttons-in-mode)
- 8. Meter Mode:** Selector switches GR meters the amount of gain reduction applied (+4 meters output level at 0 with +4 dB output; +8 meters output level at 0 with +8 dB output)
- 9. Power IEC Input:** Power input jack
- 10. Voltage Selector:** Set to correct voltage in country used in
- 11. XLR Output:** Balanced line-level output
- 12. RCA Stereo Link:** Use standard 2-conductor RCA cable for stereo linking
- 13. XLR Input:** Balanced line-level input.

**Note: For proper performance, balanced XLR must be used for all inputs and outputs.**

### All-buttons mode

By pressing in all four ratio buttons you activate what is referred to as "all buttons" mode. This "secret" mode changes the ratio to roughly 20:1. It also changes the bias of the circuit and the way that the controls interact with each other. The unit will become much more aggressive with its reaction knee becoming more like a plateau than a gentle curve and will have a more aggressive, dirty tone that sounds incredible on aggressive drums. The attack will become very punchy with a gooey "sucking" sound on the release.

### A note on Bluey's buffering:

Bluey features additional input and output buffering circuitry not found on most other compressors; as such you may find the input to run a little hotter than you might initially expect. This extra gain is useful for directly inserting Bluey in a console insert point. Additionally, it serves to model the manner in which the original Bluey was used as a console insert while also ensuring stable level balance when adjusting the Comp Mix control.

## SPECIFICATIONS

<b>Attack</b>	Continuously variable 20 $\mu$ S to 800 $\mu$ S
<b>Release</b>	Continuously variable 1200 mS to 50 mS
<b>Ratio</b>	Pushbutton selected 4:1, 8:1, 12:1, 20:1 and any combination
<b>Voltage</b>	115 VAC, 230 VAC rear panel switchable
<b>AC Mains Input</b>	IEC320-C14 standard plug
<b>Fuse</b>	50 Hz uses F2AL; both are 20 mm x 5 mm
<b>Dimensions</b>	Width 438 mm (19") Height 88 mm (2U) Depth 250 mm
<b>Weight</b>	8 kg